



TEST REPORT

Applicant: Gobel Power Energy (Shenzhen) Co., Ltd.
Address: No. 806, Block B, Huameiju Business Center, Xin'an Street, Bao'an District, Shenzhen, Guangdong, China
Manufacturer: Dongguan Zhongling Technology Co., Ltd.
Address: Room 902, Building 2, No.3, Yongtai Road, Tangxia Town, Dongguan City, Guangdong Province
EUT: Rechargeable Li-ion Battery
Trade Mark: N/A
Model Number: GP-SR1-PC314
Date of Receipt: Oct. 17, 2024
Test Date: Oct. 17, 2024 - Oct. 23, 2024
Date of Report: Oct. 23, 2024
Prepared By: Shenzhen DL Testing Technology Co., Ltd.
Address: 101-201, Comprehensive Building, Tongzhou Electronics Longgang Factory Area, No.1 Baolong Fifth Road, Baolong Community, Baolong Street, Longgang District, Shenzhen, China
Applicable Standards: EN 55032:2015+A1:2020, EN IEC 61000-3-2:2019+A1:2021, EN 61000-3-3:2013+A1:2019+A2:2021, EN 55035:2017+A11:2020, EN 61000-4-2:2009, EN IEC 61000-4-3:2020, EN 61000-4-4:2012, EN 61000-4-5:2014+A1:2017, EN IEC 61000-4-6:2023, EN 61000-4-8:2010, EN IEC 61000-4-11:2020
Test Result: Pass
Report Number: DL-241017006ER

Prepared (Engineer): HuiLian Xu

Reviewer (Supervisor): Jack Bu

Approved (Manager): Jade Yang



This test report is based on a single evaluation of one sample of above mentioned products. It is not permitted to be duplicated in extracts without written approval of Shenzhen DL Testing Technology Co., Ltd.



TABLE OF CONTENT

Test Report Declaration	Page
1. VERSION.....	3
2. TEST SUMMARY.....	3
3. GENERAL INFORMATION.....	4
4. TEST INSTRUMENT USED.....	5
5. CONDUCTED EMISSION TEST.....	7
6. RADIATION EMISSION TEST.....	9
7. HARMONIC CURRENT EMISSION TEST.....	13
8. VOLTAGE FLUCTUATIONS & FLICKER TEST.....	14
9. IMMUNITY TEST OF GENERAL THE PERFORMANCE CRITERIA.....	15
10. ELECTROSTATIC DISCHARGE IMMUNITY TEST.....	16
11. RF FIELD STRENGTH SUSCEPTIBILITY TEST.....	18
12. ELECTRICAL FAST TRANSIENT/BURST IMMUNITY TEST.....	20
13. SURGE TEST.....	21
14. INJECTED CURRENTS SUSCEPTIBILITY TEST.....	22
15. MAGNETIC FIELD IMMUNITY TEST.....	23
16. VOLTAGE DIPS AND INTERRUPTIONS TEST.....	24
17. EUT PHOTOGRAPHS.....	25

**1. VERSION**

Version No.	Date	Description
00	Oct. 23, 2024	Original

2. TEST SUMMARY

EMC Emission				
Standard	Test Item	Limit	Result	Remark
EN 55032	Conducted Emission at power ports	Class B	N/A	
	Conducted Emission at LAN port	Class B	N/A	
	Radiated Emission below 1GHz	Class B	PASS	
	Radiated Emission above 1GHz	Class B	N/A	
EN 61000-3-2	Harmonic Current Emission	Class A or D	N/A ^{NOTE (2)}	
EN 61000-3-3	Voltage Fluctuations & Flicker	-----	N/A	
EMC Immunity				
Section EN 55035	Test Item	Performance Criteria	Result	Remark
EN 61000-4-2	Electrostatic Discharge	B	PASS	
EN 61000-4-3	RF electromagnetic field	A	PASS	
EN 61000-4-4	Fast transients	B	N/A	
EN 61000-4-5	Surges	B	N/A	
EN 61000-4-6	Injected Current	A	N/A	
EN 61000-4-8	Power Frequency Magnetic Field	A	PASS	
EN 61000-4-11	Volt. Interruptions Volt. Dips	B / C / C ^{NOTE (3)}	N/A	

NOTE:

(1) "N/A" denotes test is not applicable in this Test Report

(2) The power consumption of EUT is less than 75W and no Limits apply.

(3) Voltage dip: 100% reduction – Performance Criteria B

Voltage dip: 30% reduction – Performance Criteria C

Voltage Interruption: 100% Interruption – Performance Criteria C

(4) Test Facility: Shenzhen DL Testing Technology Co., Ltd.

Address: 101-201, Comprehensive Building, Tongzhou Electronics Longgang Factory Area, No.1
Baolong Fifth Road, Baolong Community, Baolong Street, Longgang District, Shenzhen, China



3. GENERAL INFORMATION

3.1 Description of Device (EUT)

EUT: Rechargeable Li-ion Battery

Trade Mark: N/A

Model Number: GP-SR1-PC314

Test Model: GP-SR1-PC314

Model difference: N/A

Power Supply: DC 51.2V

Working Frequency: Below 108MHz

NOTE:

(1) For a more detailed features description, please refer to the manufacturer's specifications or the User's Manual.

(2) The EUT's all information provided by client.

3.2 Tested System Details

None.

3.3 Block Diagram of Test Set-up

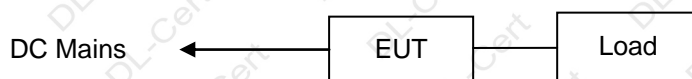

3.4 Test Mode Description

Mode1. On Mode

3.5 Test Auxiliary Equipment

None.

3.6 Test Uncertainty

Conducted Emission Uncertainty : $\pm 2.56\text{dB}$

Radiated Emission Uncertainty : $\pm 3.24\text{dB}$

**4. TEST INSTRUMENT USED****For Conducted Emission Test (843 Shielded Room)**

Equipment	Manufacturer	Model	Serial	Last Cal.	Next Cal.
843 Shielded Room	YIHENG	843 Room	843	Nov. 05, 2023	Nov. 04, 2026
EMI Receiver	R&S	ESR	101421	Nov. 04, 2023	Nov. 03, 2024
LISN	R&S	ENV216	102417	Nov. 04, 2023	Nov. 03, 2024
Clamp	COM-POWER	CLA-050	431072	Nov. 04, 2023	Nov. 03, 2024
3-Loop Antenna	DAZE	ZN30401	13021	Nov. 04, 2023	Nov. 03, 2024
ISN T8	Schwarzbeck	NTFM 8158	101135	Nov. 04, 2023	Nov. 03, 2024
ISN T5	Schwarzbeck	NTFM 8158	101136	Nov. 04, 2023	Nov. 03, 2024
843 Cable 1#	ChengYu	CE Cable	001	Nov. 04, 2023	Nov. 03, 2024
843 Cable 1#	ChengYu	CE Cable	002	Nov. 04, 2023	Nov. 03, 2024

For Radiated Emission Test (966 chamber)

Equipment	Manufacturer	Model	Serial	Last Cal.	Next Cal.
966 chamber	YIHENG	966 Room	966	Nov. 06, 2023	Nov. 05, 2026
Spectrum Analyzer	Agilent	E4408B	MY50140780	Nov. 04, 2023	Nov. 03, 2024
EMI Receiver	R&S	ESRP7	101393	Nov. 04, 2023	Nov. 03, 2024
Amplifier	Schwarzbeck	BBV9743B	00153	Nov. 04, 2023	Nov. 03, 2024
Amplifier	EMEC	EM01G8GA	00270	Nov. 04, 2023	Nov. 03, 2024
Broadband Trilog Antenna	Schwarzbeck	VULB9162	00306	Nov. 04, 2023	Nov. 03, 2024
Horn Antenna	Schwarzbeck	BBHA9120D	02139	Nov. 04, 2023	Nov. 03, 2024
966 Cable 1#	ChengYu	966	004	Nov. 04, 2023	Nov. 03, 2024
966 Cable 2#	ChengYu	966	003	Nov. 04, 2023	Nov. 03, 2024

For Harmonic & Flicker Test (EMS --- site)

Equipment	Manufacturer	Model	Serial	Last Cal.	Next Cal.
Harmonics, Flicker & power Analyser	LAPLACE INSTRUMENTS	AC2000A	311370	Nov. 04, 2023	Nov. 03, 2024
AC Power Supply	MToni	HPF5010	633659	Nov. 04, 2023	Nov. 03, 2024

For Electrostatic Discharge Immunity Test (EMS --- site)

Equipment	Manufacturer	Model	Serial	Last Cal.	Next Cal.
ESD Tester	SCHLODER	SESD 230	17352	Nov. 04, 2023	Nov. 03, 2024

**For RF Field Strength Susceptibility Test (Keyway --- site)**

Equipment	Manufacturer	Model	Serial	Last Cal.	Next Cal.
Signal Generator	HP	8648A	3625U00573	Apr. 11, 2024	Apr. 11, 2025
Amplifier	A&R	500A100	17034	Apr. 11, 2024	Apr. 11, 2025
Amplifier	A&R	100W/1000M1	17028	Apr. 11, 2024	Apr. 11, 2025
Audio Analyzer (20Hz~1GHz)	Panasonic	2023B	202301/428	Apr. 11, 2024	Apr. 11, 2025
Isotropic Field Probe	A&R	FP2000	16755	Apr. 11, 2024	Apr. 11, 2025
Antenna	EMCO	3108	9507-2534	Apr. 11, 2024	Apr. 11, 2025
Log-periodic Antenna	A&R	AT1080	16812	Apr. 11, 2024	Apr. 11, 2025

For EFT /B, Surge, Voltage Dips Interruptions Test (EMS --- site)

Equipment	Manufacturer	Model	Serial	Last Cal.	Next Cal.
Transient Comprehensive Immunity Test System	Graphtec	HVIP16T+HCO MPACT 5	192501+192202	Nov. 04, 2023	Nov. 03, 2024
Coupling Clamp	HTEC	001	0001	Nov. 04, 2023	Nov. 03, 2024

For Injected Currents Susceptibility Test (EMS --- site)

Equipment	Manufacturer	Model	Serial	Last Cal.	Next Cal.
C/S Test System	LIONCEL	RIS-6091-85	0191101	Nov. 04, 2023	Nov. 03, 2024
CDN	LIONCEL	CDN-M2-16	0191001	Nov. 04, 2023	Nov. 03, 2024
CDN	LIONCEL	CDN-M3-16	0191002	Nov. 04, 2023	Nov. 03, 2024
Injection Clamp	Frankonia	EMCL-20	18101728-0108	Nov. 04, 2023	Nov. 03, 2024

For Magnetic Field Immunity Test (EMS --- site)

Equipment	Manufacturer	Model	Serial	Last Cal.	Next Cal.
Magnetic field Test System	LIONCEL	PMF-801C-C/ PMF-801C-T	190401	Nov. 04, 2023	Nov. 03, 2024

Other

Item	Name	Manufacturer	Model	Software version
1	EMC Conduction Test System	FALA	EZ_EMCC	EMC-CON 3A1.1
2	EMC radiation test system	FALA	EZ_EMCC	FA-03A2
3	Harmonic test system	LAPLACE INSTRUMENTS	Harmonic	1.0.0.0
4	RF Immunity test system	LIONCEL	C/S	1.1.0.0

5. CONDUCTED EMISSION TEST

5.1 Block Diagram of Test Setup

For Mains Terminals Test

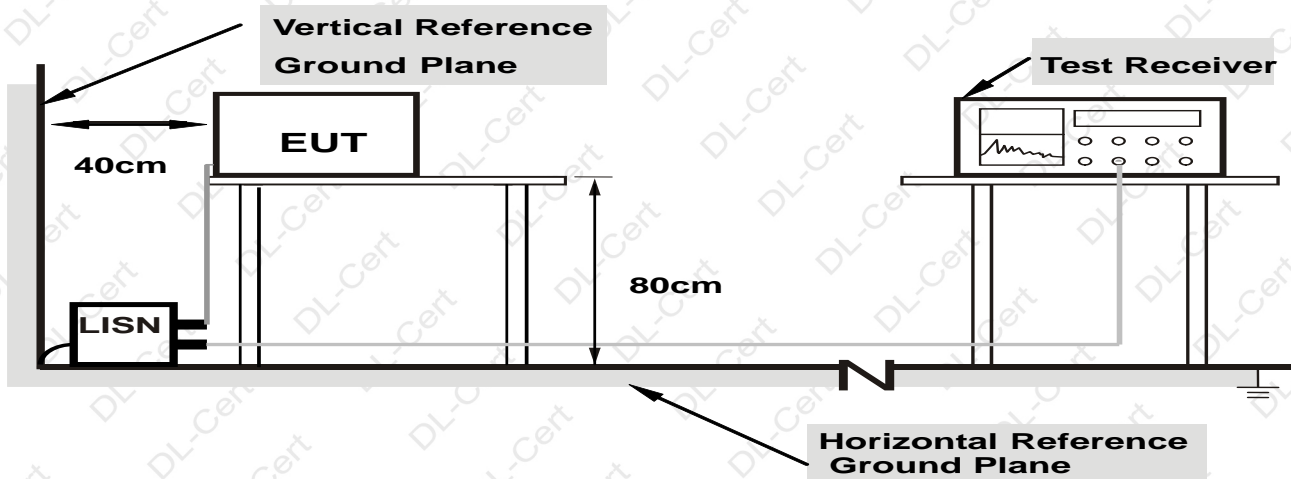

Note: 1.Support units were connected to second LISN.

2.Both of LISNs (AMN) are 80 cm from EUT and at least 80 cm from other units and other metal planes

For Telecom Port Test

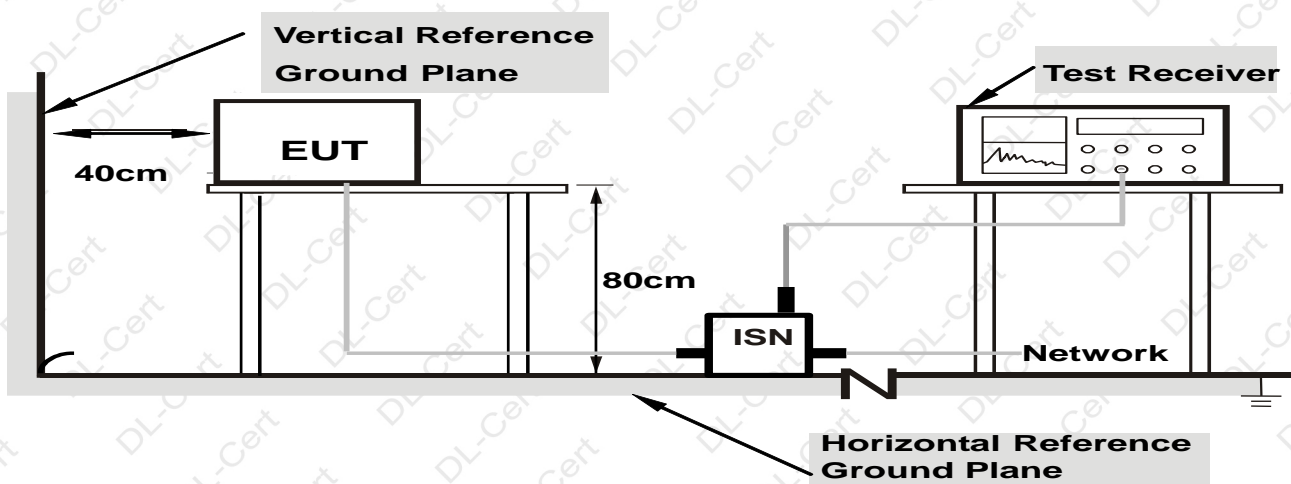

Note: 1.Support units were connected to second LISN.

2.Both of ISNs are 80 cm from EUT and at least 80 cm from other units and other metal planes



5.2 Test Standard and Limit

EN 55032

For Mains Terminals Test			For Telecom Port Test		
Frequency MHz	Limits dB(μ V)		Frequency MHz	Limits dB(μ V)	
	Quasi-peak Level	Average Level		Quasi-peak Level	Average Level
0.15~0.50	66 ~ 56*	55 ~ 46*	0.15~0.50	84 ~ 74*	74 ~ 64*
0.50~5.00	56	46	0.50~30.00	74	64
5.00~30.00	60	50	/	/	/

Notes: 1. *Decreasing linearly with logarithm of frequency.
2. The lower limit shall apply at the transition frequencies.

5.3 EUT Configuration on Test

The following equipment's are installed on conducted emission test to meet EN 55032 requirement and operating in a manner which tends to maximize its emission characteristics in a normal application.

5.4 Operating Condition of EUT

5.4.1 Setup the EUT and simulators as shown in Section 5.1.

5.4.2 Turn on the power of all equipments.

5.4.3 Let the EUT work in test modes and test it.

5.5 Test Procedure

The EUT is put on the table and connected to the AC mains through a Artificial Mains Network (AMN) or ISN. This provided a 50ohm coupling impedance for the tested equipments. Both sides of AC line are checked to find out the maximum conducted emission levels according to the **EN 55032** regulations during conducted emission test.

The bandwidth of the test receiver (R&S Test Receiver ESR) is set at 10KHz.

The frequency ranges from 150kHz to 30MHz is investigated.

5.6 Test Result

The EUT is powered by DC, no requirements for this item.

6. RADIATION EMISSION TEST

6.1 Block Diagram of Test Setup

Below 1GHz

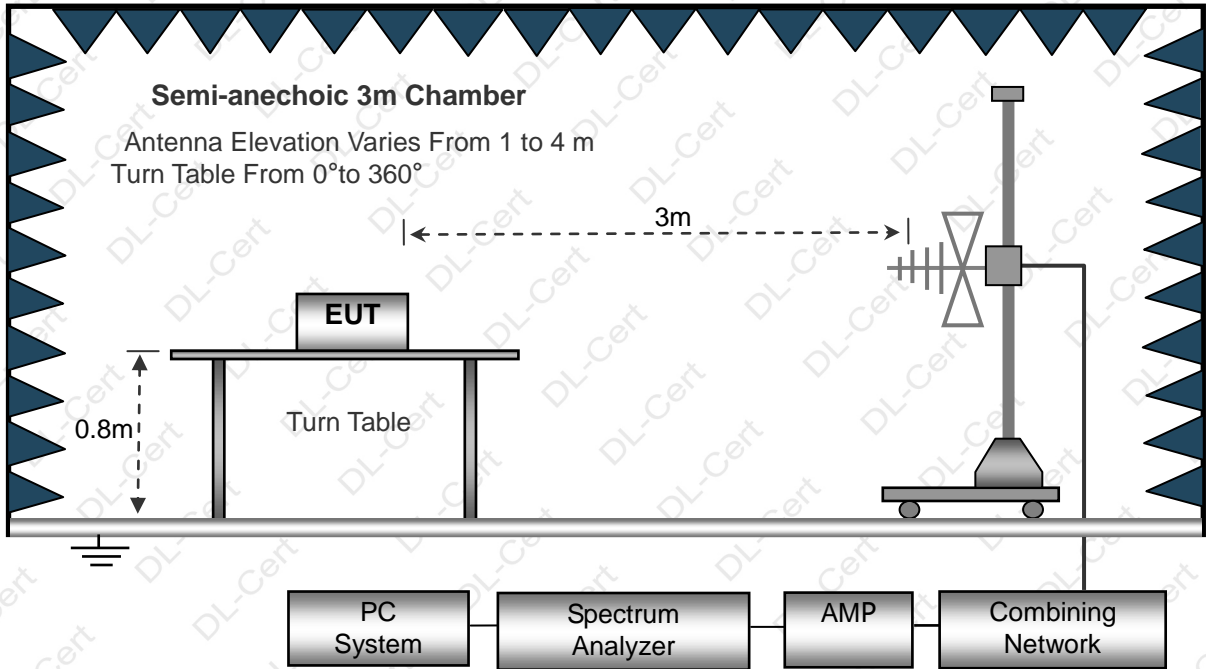

Above 1GHz

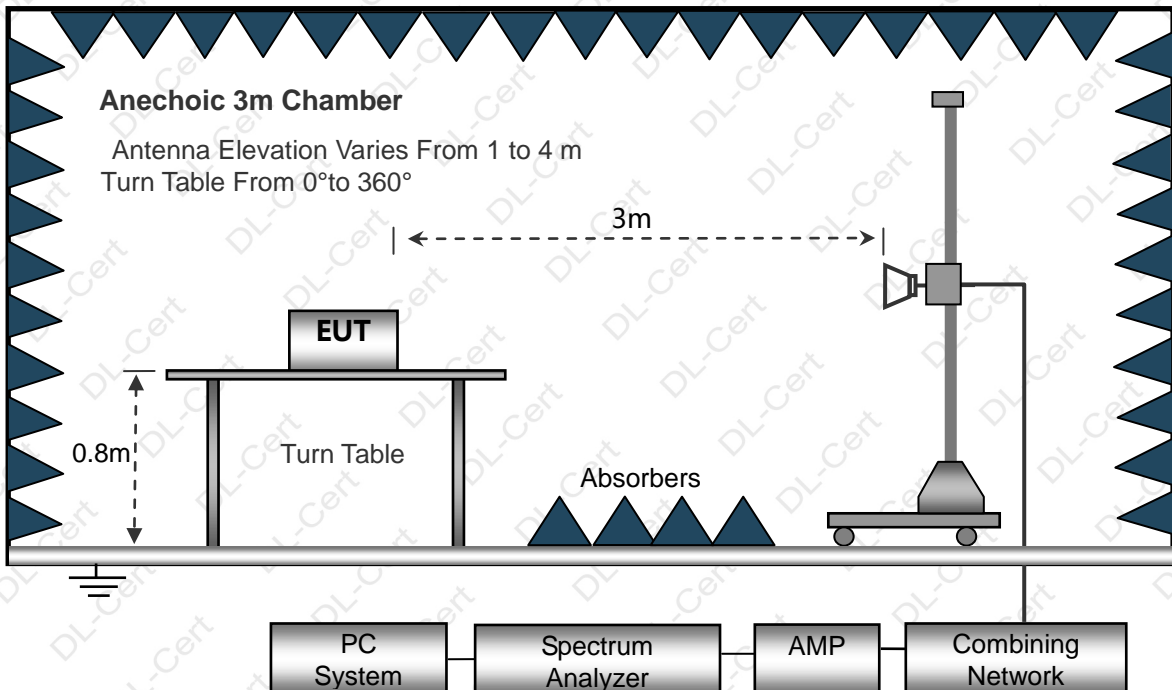

6.2 Test Standard and Limit

EN 55032



Below 1GHz

Equipment type	Distance (Meters)	Frequency MHz	Limit values dB(μ V/m) Quasi-peak
FM receivers	3	$\leq 1\ 000$	Fundamental 60
		30 to 230	Harmonics 52
		230 to 300	Harmonics 52
		300 to 1 000	Harmonics 56
Other	3	30 to 230	40
		230 to 1 000	47

Above 1GHz

Frequency MHz	Distance (Meters)	Field Strengths Limits dB(μ V/m)	Detector
1000~3000	3	70.0	PEAK
1000~3000	3	50.0	AVERAGE
3000~6000	3	74.0	PEAK
3000~6000	3	54.0	AVERAGE

Remark:

(1) The smaller limit shall apply at the cross point between two frequency bands.

(2) Distance refers to the distance in meters between the measuring instrument, antenna and the closed point of any part of the device or system.

6.3 EUT Configuration on Test

The EN 55032 regulations test method must be used to find the maximum emission during radiated emission test.

The configuration of EUT is the same as used in conducted emission test. Please refer to Section 5.3.

6.4 Operating Condition of EUT

Same as conducted emission test, which is listed in Section 5.4 except the test set up replaced as Section 6.2.

6.5 Test Procedure

- 1) The radiated emissions test was conducted in a semi-anechoic chamber.
- 2) The tabletop EUT was placed upon a non-metallic table 0.8m above the ground reference plane. And for floor-standing arrangement, the EUT was placed on the horizontal ground reference plane, but separated from metallic contact with the ground reference plane by 0.1m of insulation.
- 3) Before final measurements of radiated emissions, a pre-scan was performed in the spectrum mode with the peak detector to find out the maximum emissions spectrum plots of the EUT.
- 4) The frequencies of maximum emission were determined in the final radiated emissions measurement. At each frequency, the EUT was rotated 360°, and the antenna was raised and lowered from 1 to 4 meters in order to determine the maximum disturbance. Measurements were performed for both horizontal and vertical antenna polarization.
- 5) The bandwidth setting on the field strength meter (R&S Test Receiver ESCI) is set at 120KHz.
- 6) The frequency range from 30MHz to 1000MHz is checked.

6.6 Test Result

PASS

Please refer to the following page.



Radiation Emission Test Data			
Temperature:	24.5°C	Relative Humidity:	54%
Pressure:	1009hPa	Polarization:	Horizontal
Test Voltage:	DC 51.2V	Test Mode:	Mode 1

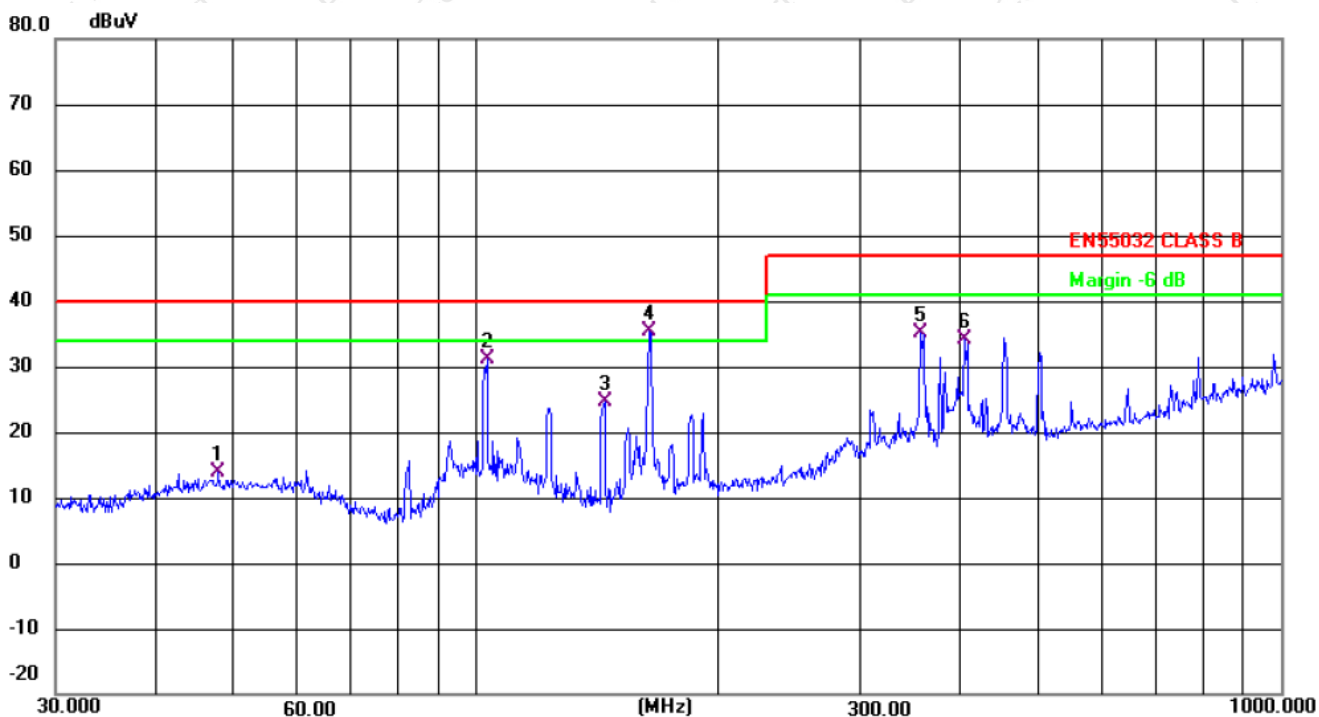

No.	Mk.	Freq. MHz	Reading Level dBuV	Correct Factor dB	Measure- ment dBuV	Limit dB	Margin dB	Detector
1		47.8260	26.82	-13.06	13.76	40.00	-26.24	QP
2		103.0800	45.88	-14.78	31.10	40.00	-8.90	QP
3		144.3348	43.02	-18.45	24.57	40.00	-15.43	QP
4	*	164.3301	52.74	-17.40	35.34	40.00	-4.66	QP
5		356.6758	45.60	-10.52	35.08	47.00	-11.92	QP
6		404.6665	43.53	-9.44	34.09	47.00	-12.91	QP

Remark:

Correct Factor=Cable loss+Antenna factor-Preamplifier

Measurement Level = Reading Level + Correct Factor; Margin = Measurement Level- Limit;



Radiation Emission Test Data			
Temperature:	24.5°C	Relative Humidity:	54%
Pressure:	1009hPa	Polarization:	Vertical
Test Voltage:	DC 51.2V	Test Mode:	Mode 1

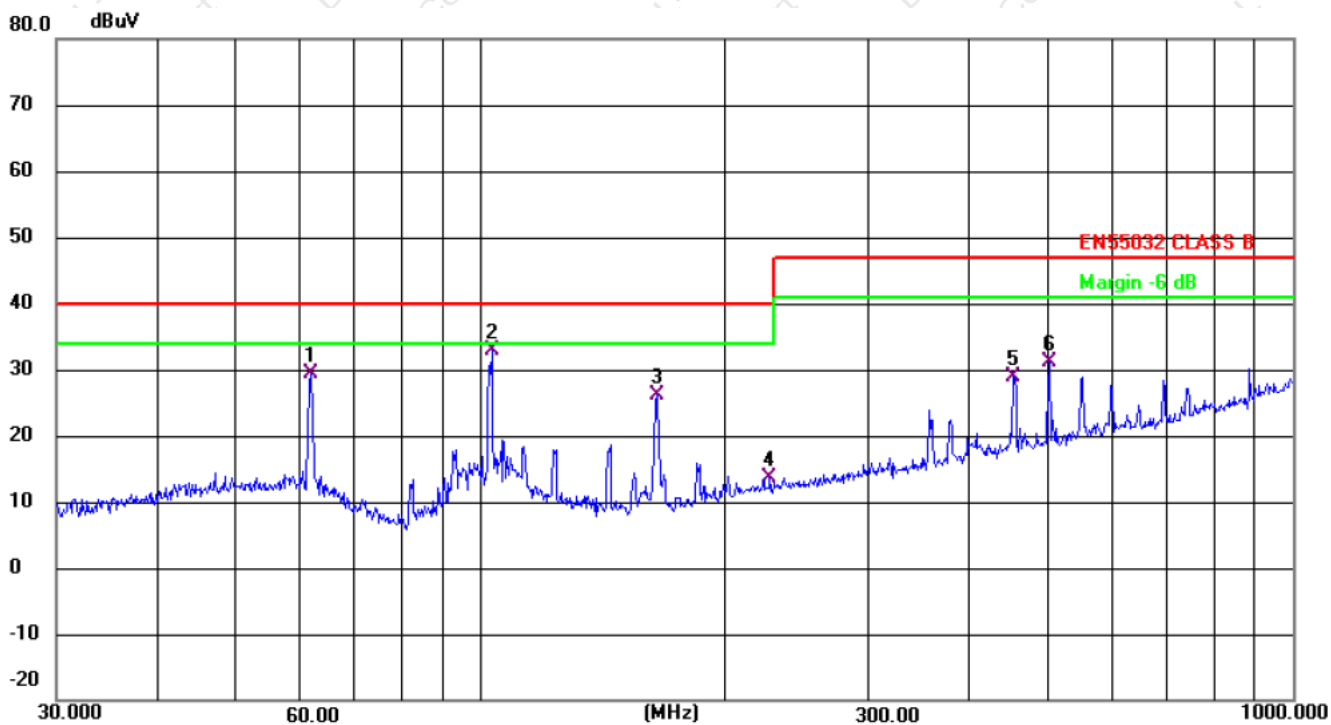

No.	Mk.	Freq. MHz	Reading Level dBuV	Correct Factor dB	Measure- ment dBuV	Limit dB	Margin dB	Detector
1		61.7781	43.51	-14.24	29.27	40.00	-10.73	QP
2	*	103.0800	47.75	-14.78	32.97	40.00	-7.03	QP
3		164.9075	43.46	-17.45	26.01	40.00	-13.99	QP
4		226.8936	27.67	-13.98	13.69	40.00	-26.31	QP
5		452.7197	37.02	-8.10	28.92	47.00	-18.08	QP
6		501.1790	38.54	-7.37	31.17	47.00	-15.83	QP

Remark:

Correct Factor=Cable loss+Antenna factor-Preamplifier

Measurement Level = Reading Level + Correct Factor; Margin = Measurement Level- Limit;



7. HARMONIC CURRENT EMISSION TEST

7.1 Block Diagram of Test Setup

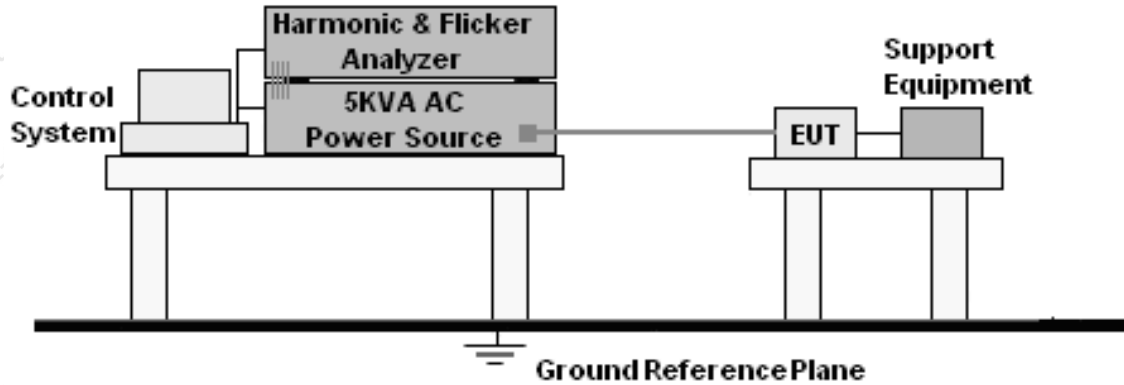

7.2 Test Standard

EN 61000-3-2

7.3 Operating Condition of EUT

Setup the EUT as shown in Section 5.1.

Turn on the power of all equipment.

Let the EUT work in test mode and test it.

7.4 Test Procedure

The power cord of the EUT is connected to the output of the test system. Turn on the power of the EUT and use the test system to test the harmonic current level.

7.5 Test Results

The EUT is powered by DC, no requirements for this item.



8. VOLTAGE FLUCTUATIONS & FLICKER TEST

8.1 Block Diagram of Test Setup

Same as Section 7.1.

8.2 Test Standard

EN 61000-3-3

8.3 Operating Condition of EUT

Same as Section 7.3. The power cord of the EUT is connected to the output of the test system. Turn on the power of the EUT and use the test system to test the harmonic current level.

Flicker Test Limit

Test items	Limits
Pst	1.0
dc	3.3%
Tmax	4.0%
dt	Not exceed 3.3% for 500ms

8.4 Test Procedure

The power cord of the EUT is connected to the output of the test system. Turn on the power of the EUT and use the test system to test the harmonic current level.

8.5 Test Results

The EUT is powered by DC, no requirements for this item.

**9. IMMUNITY TEST OF GENERAL THE PERFORMANCE CRITERIA**

Product Standard	EN 55035
CRITERION A	<p>The equipment shall continue to operate as intended without operator intervention. No degradation of performance, loss of function or change of operating state is allowed below a performance level specified by the manufacturer when the equipment is used as intended. The performance level may be replaced by a permissible loss of performance. If the minimum performance level or the permissible performance loss is not specified by the manufacturer, then either of these may be derived from the product description and documentation, and by what the user may reasonably expect from the equipment if used as intended.</p>
CRITERION B	<p>During the application of the disturbance, degradation of performance is allowed. However, no unintended change of actual operating state or stored data is allowed to persist after the test.</p> <p>After the test, the equipment shall continue to operate as intended without operator intervention; no degradation of performance or loss of function is allowed, below a performance level specified by the manufacturer, when the equipment is used as intended. The performance level may be replaced by a permissible loss of performance.</p> <p>If the minimum performance level (or the permissible performance loss), or recovery time, is not specified by the manufacturer, then either of these may be derived from the product description and documentation, and by what the user may reasonably expect from the equipment if used as intended.</p>
CRITERION C	<p>Loss of function is allowed, provided the function is self-recoverable, or can be restored by the operation of the controls by the user in accordance with the manufacturer's instructions. A reboot or re-start operation is allowed.</p> <p>Information stored in non-volatile memory, or protected by a battery backup, shall not be lost.</p>

10. ELECTROSTATIC DISCHARGE IMMUNITY TEST

10.1 Block Diagram of Test Setup

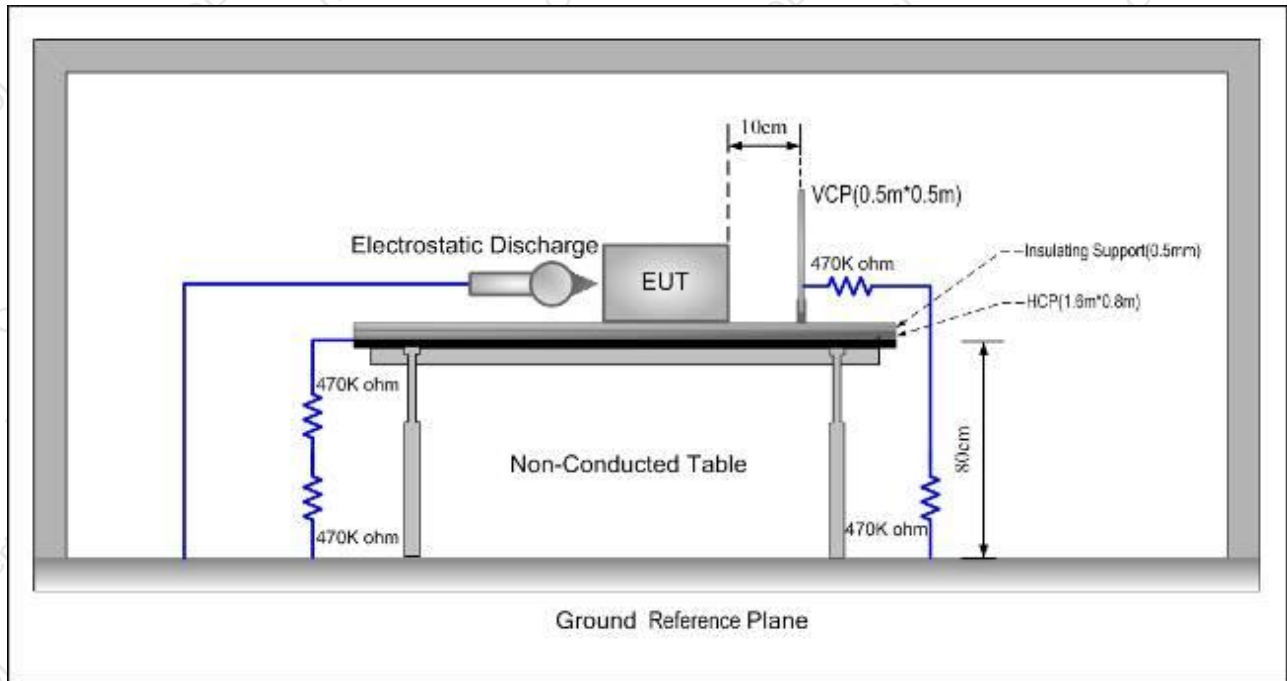

10.2 Test Standard

EN 55035, EN 61000-4-2

10.3 Severity Levels and Performance Criterion

Severity Level: 3 / Air Discharge: $\pm 8\text{KV}$

Level: 2 / Contact Discharge: $\pm 4\text{KV}$

Performance criterion : B

10.4 Test Procedure

- Electrostatic discharges were applied only to those points and surfaces of the Product that are accessible to users during normal operation.
- The test was performed with at least ten single discharges on the pre-selected points in the most sensitive polarity.
- The time interval between two successive single discharges was at least 1 second.
- The ESD generator was held perpendicularly to the surface to which the discharge was applied and the return cable was at least 0.2 meters from the Product.
- Contact discharges were applied to the non-insulating coating, with the pointed tip of the generator penetrating the coating and contacting the conducting substrate.
- Air discharges were applied with the round discharge tip of the discharge electrode approaching the Product as fast as possible (without causing mechanical damage) to touch the Product. After each discharge, the ESD generator was removed from the Product and re-triggered for a new single discharge. The test was repeated until all discharges were complete.
- At least ten single discharges (in the most sensitive polarity) were applied to the Horizontal Coupling Plane at points on each side of the Product. The ESD generator was positioned vertically at a distance of 0.1 meters from the Product with the discharge electrode touching the HCP.



- h. At least ten single discharges (in the most sensitive polarity) were applied to the center of one vertical edge of the Vertical Coupling Plane in sufficiently different positions that the four faces of the Product were completely illuminated. The VCP (dimensions 0.5m x 0.5m) was placed vertically to and 0.1 meters from the Product.

10.5 Test Results

PASS

Please refer to the following page.

Electrostatic Discharge Test Data					
Temperature:	25.1 °C	Humidity:	55%		
Power Supply:	DC 51.2V	Test Mode:	Mode 1		
Discharge Method	Discharge Position	Voltage (±kV)	Min. No. of Discharge per polarity (Each Point)	Required Level	Result
Contact Discharge	Conductive Surfaces	4	25	B	Pass
	Indirect Discharge HCP	4	25	B	Pass
	Indirect Discharge VCP	4	25	B	Pass
Air Discharge	Slots, Apertures, and Insulating Surfaces	8	10	B	Pass

Note: N/A

11. RF FIELD STRENGTH SUSCEPTIBILITY TEST

11.1 Block Diagram of Test Setup

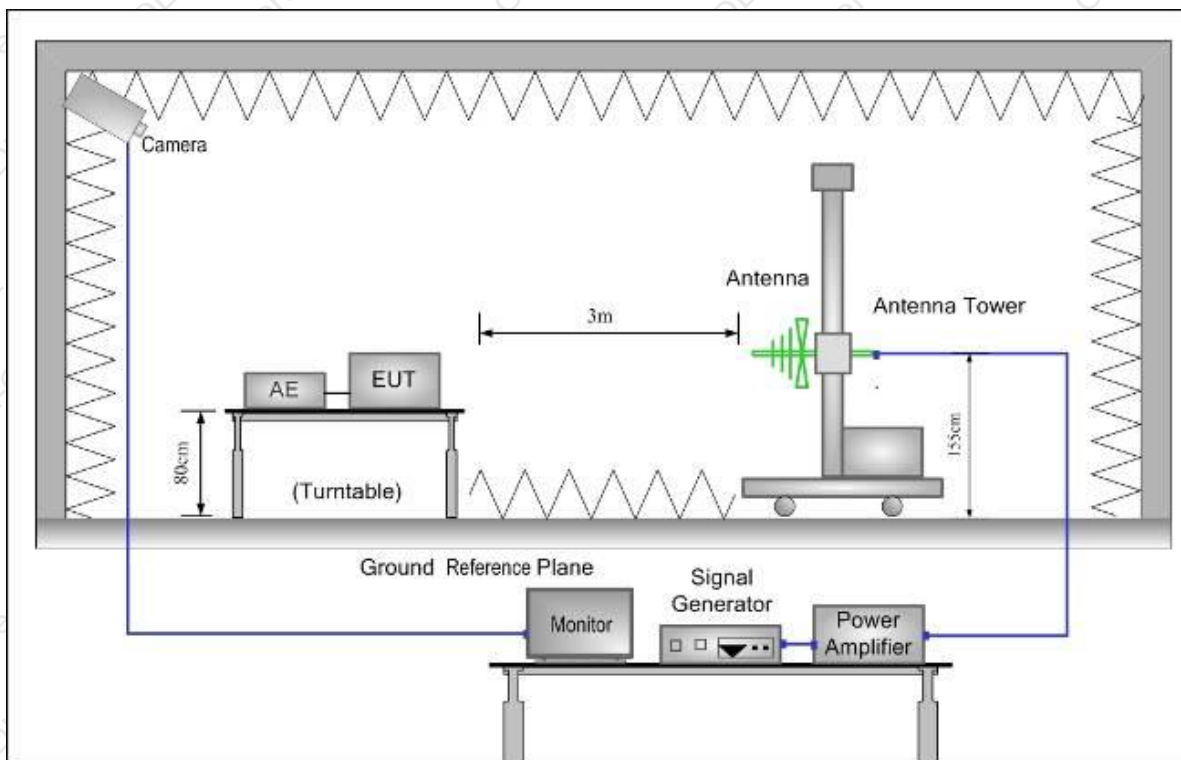

11.2 Test Standard

EN 55035, EN 61000-4-3

11.3 Severity Levels and Performance Criterion

Severity Level 2, 3V / m

Performance criterion: A

11.4 Test Procedure

The EUT and its simulators are placed on a turn table which is 0.8 meter above ground. EUT is set 3 meter away from the transmitting antenna which is mounted on an antenna tower. Both horizontal and vertical polarization of the antenna are set on test. Each of the four sides of EUT must be faced this transmitting antenna and measured individually.

All the scanning conditions are as follows:

Condition of Test	Remarks
Fielded Strength	3 V/m (Severity Level 2)
Radiated Signal	Modulated
Scanning Frequency	80 – 6000 MHz
Dwell time of radiated	0.0015 decade/s
Waiting Time	1 Sec.



11.5 Test Results

PASS

Please refer to the following page.

R/S Test Data				
Temperature:	25.1°C	Humidity:	55%	
Power Supply :	DC 51.2V	Test Mode:	Mode 1	
Criterion:	A	Steps	1 %	
Frequency (MHz)	Position	Field Strength (V/m)	Required Level	Result
80 – 1000 1800 2600 3500 5000	Front, Right, Back, Left	3	A	Pass
Note: N/A				

12. ELECTRICAL FAST TRANSIENT/BURST IMMUNITY TEST

12.1 Block Diagram of EUT Test Setup

For input a.c. / d.c. power port:

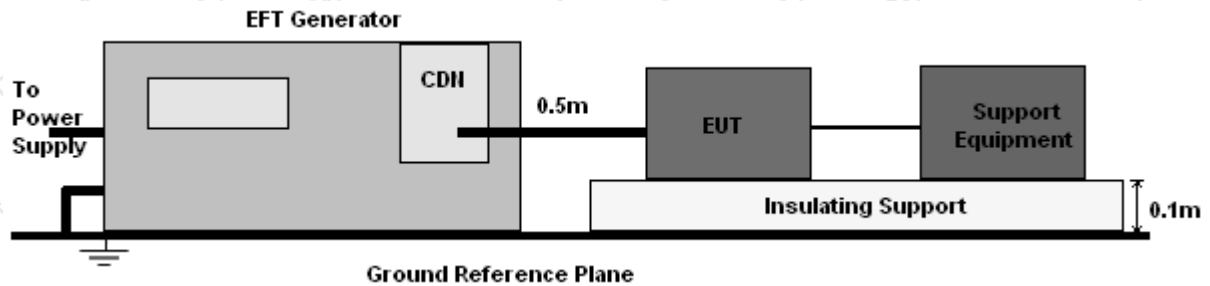

For signal lines and control lines:

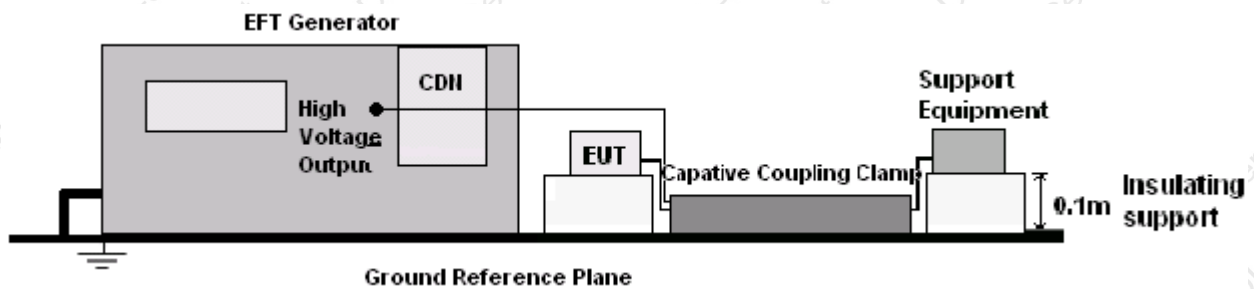

12.2 Test Standard

EN 55035, EN 61000-4-4

12.3 Severity Levels and Performance Criterion

Severity Level 2 at 1KV, Pulse Rise time & Duration: 5 nS / 50 nS

Performance criterion: B

12.4 Test Procedure

EUT shall be placed 0.8m high above the ground reference plane which is a min.1m*1m metallic sheet with 0.65mm minimum thickness. This reference ground plane shall project beyond the EUT by at least 0.1m on all sides and the minimum distance between EUT and all other conductive structure, except the ground plane beneath the EUT, shall be more than 0.5m

For input and output AC power ports:

The EUT is connected to the power mains by using a coupling device which couples the EFT interference signal to AC power lines. Both polarities of the test voltage should be applied during compliance test and the duration of the test is 2 minutes.

12.5 Test Results

The EUT is powered by DC, no requirements for this item.

13. SURGE TEST

13.1 Block Diagram of EUT Test Setup

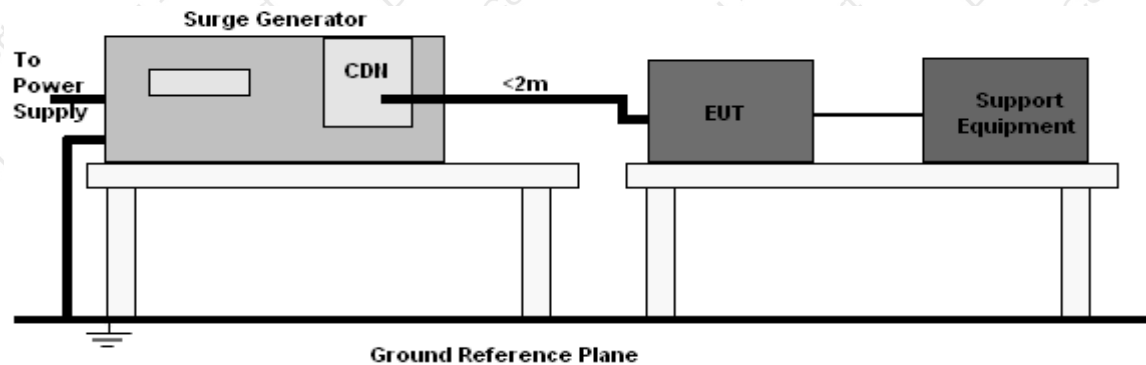

13.2 Test Standard

EN 55035, EN61000-4-5

13.3 Severity Levels and Performance Criterion

Severity Level: Line to Line, Level 2 at 1KV;

Severity Level: Line to Earth, Level 3 at 2KV.

Performance criterion: B

13.4 Test Procedure

- 1) Set up the EUT and test generator as shown on section 11.1
- 2) For line to line coupling mode, provide a 1KV 1.2/50us voltage surge (at open-circuit condition) and 8/20us current surge to EUT selected points.
- 3) At least 5 positive and 5 negative (polarity) tests with a maximum 1/min repetition rate are conducted during test.
- 4) Different phase angles are done individually.
- 5) Repeat procedure 2) to 4) except the open-circuit test voltage change from 1KV to 2KV for line to earth coupling mode test.
- 6) Record the EUT operating situation during compliance test and decide the EUT immunity criterion for above each test.

13.5 Test Result

The EUT is powered by DC, no requirements for this item.

14. INJECTED CURRENTS SUSCEPTIBILITY TEST

14.1 Block Diagram of EUT Test Setup

For input a.c. / d.c. power port:

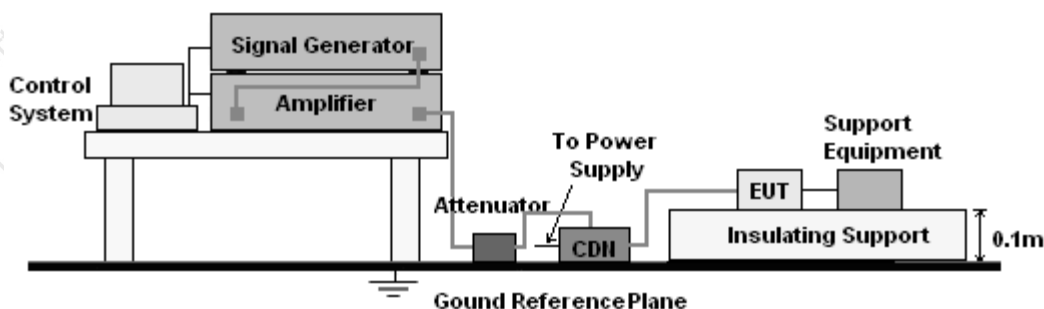

For signal lines and control lines:

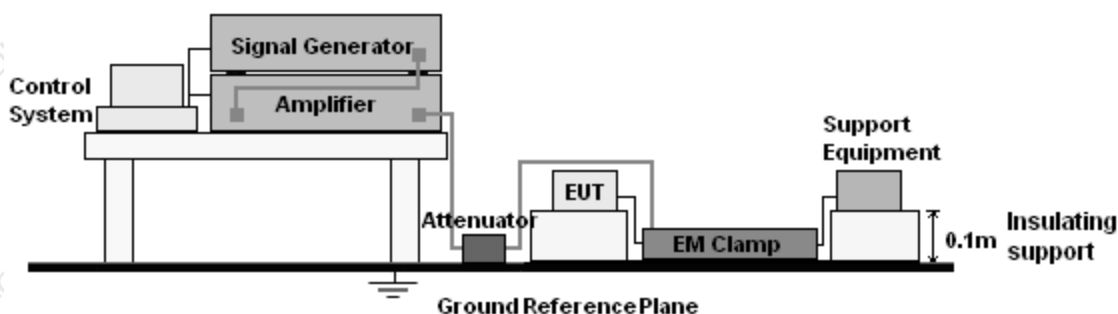

14.2 Test Standard

EN 55035, EN61000-4-6

14.3 Severity Levels and Performance Criterion

Severity Level 2: 3V(rms), 150KHz ~ 80MHz

Performance criterion: A

14.4 Test Procedure

- 1) Set up the EUT, CDN and test generator as shown on section 12.1.
- 2) Let EUT work in test mode and measure.
- 3) The EUT and supporting equipment are placed on an insulating support 0.1m high above a ground reference plane. CDN (coupling and decoupling device) is placed on the ground plane at above 0.1-0.3m from EUT. Cables between CDN and EUT are as short as possible, and their height above the ground reference plane shall be between 30 and 50 mm (where possible).
- 4) The disturbance signal described below is injected to EUT through CDN.
- 5) The EUT operates within its operational mode(s) under intended climatic conditions after power on.
- 6) The frequency range is swept from 150KHz to 80MHz using 3V signal level, and with the disturbance signal 80% amplitude modulated with a 1KHz sine wave
- 7) The rate of sweep shall not exceed 1.5×10^{-3} decades/s. Where the frequency is swept incrementally, the step size shall not exceed 1% of the start and thereafter 1% of the preceding frequency value.
- 8) Recording the EUT operating situation during compliance test and decide the EUT immunity criterion for above each test.

14.5 Test Result

The EUT is powered by DC, no requirements for this item.



15. MAGNETIC FIELD IMMUNITY TEST

15.1 Block Diagram of EUT Test Setup

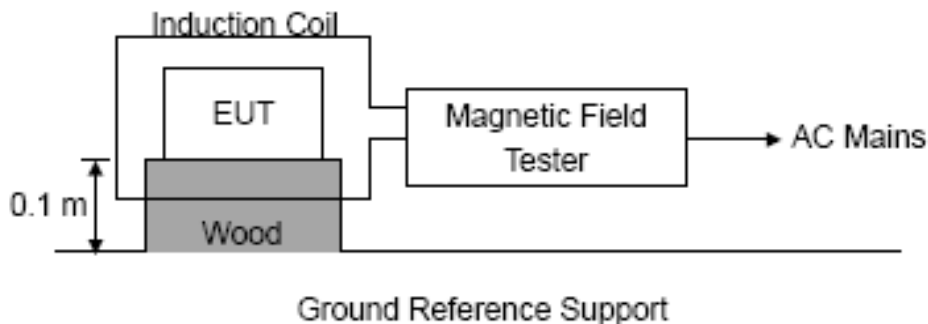

15.2 Test Standard

EN 55035, EN61000-4-8

15.3 Severity Levels and Performance Criterion

Severity Level 1: 1A/m

Performance criterion: B

15.4 Test Procedure

The EUT shall be subjected to the test magnetic field by using the induction coil of standard dimensions (1m*1m) and shown in Section 13.1. The induction coil shall then be rotated by 90° in order to expose the EUT to the test field with different orientations.

15.5 Test Result

PASS

Please refer to the following page.

MS Test Data					
Temperature:	24.5°C		Humidity:	53%	
Power Supply :	DC 51.2V		Test Mode:	Mode 1	
Environmental Phenomena	Test specification	Units	Coil Orientation	Performance Criterion	Result
Magnetic Field	1	A/m	X	A	PASS
			Y	A	PASS
			Z	A	PASS
Note: N/A					



16. VOLTAGE DIPS AND INTERRUPTIONS TEST

16.1 Block Diagram of EUT Test Setup

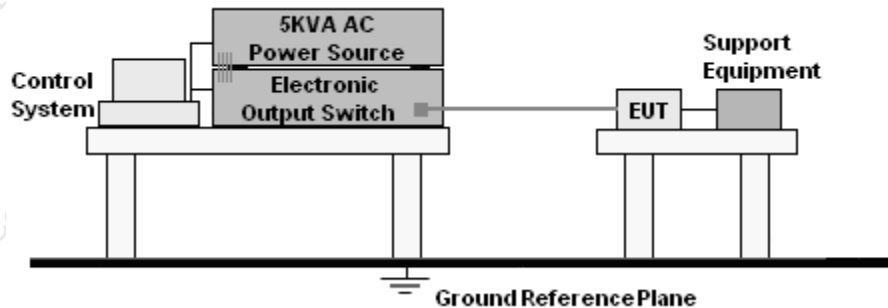

16.2 Test Standard

EN 55035, EN61000-4-11

16.3 Severity Levels and Performance Criterion

Input and Output AC Power Ports.

- Voltage Dips.
- Voltage Interruptions.

Environmental Phenomena	Test Specification	Units	Performance Criterion
Voltage Dips	>95	% Reduction period	B
	0.5		
Voltage Interruptions	30	% Reduction period	C
	25		
Voltage Interruptions	>95	% Reduction period	C
	250		

16.4 Test Procedure

- 1) Set up the EUT and test generator as shown on section 14.1
- 2) The interruption is introduced at selected phase angles with specified duration. There is a 3mins minimum interval between each test event.
- 3) After each test a full functional check is performed before the next test.
- 4) Repeat procedures 2 & 3 for voltage dips, only the level and duration is changed.
- 5) Record any degradation of performance.

16.5 Test Result

The EUT is powered by DC, no requirements for this item.



17. EUT PHOTOGRAPHS



Gobel Power Rechargeable Li-ion Battery

IFpP/72/174/208/[16S1P]M/-10+50/95

Model	GP-SR1-PC314
Battery Type	LiFePO4
Battery Energy	16.07kWh
Nominal Voltage	51.2VDC
Capacity	314Ah
Max Charge Voltage	58.4VDC
Max Charge Current	150A
Max Discharge Current	150A
Parallel Connection (Max)	15P
Series Connection	NO
Active Balance	4A
Ingress Protection	IP21
Operating Temperature Range	Charge: 0 - 55°C Discharge: -20 - 55°C

***** END OF REPORT *****